

PSX SERIES - General Purpose, 105°C

- Minimum Continuous Load Life: 1000 hours at 105°C
- For Power Supplies, Inverters, SMPS
- Snap-in Terminals
- Top Vent for Safety



SPECIFICATIONS

	Parameter	Performance					
1	Operating Temperature Range	- 25° C ~ 105° C					
2	Rated Voltage Range	16 V to 450 V					
3	Capacitance Tolerance	± 20%					
4	Leakage Current (Max) - Apply Rated Voltage for 5 minutes before test	I = 0.02 CV or 5 mA, whichever is smaller					
		I = Leakage Current; C = Rated Capacitance; V = Rated Working Voltage					
5	Dissipation Factor (% , max at 100 Hz)	Vdc	16	25-35	50-100	160-400	450
		Max Rating	40	30	20	15	20
6	Temperature Characteristics Impedance Ratio (max)	Vdc	16	25-35	50-100	160-400	450
		Z _{-25°C} / Z _{20°C}	4	3	2	4	8
7	Endurance	After 1000 Hours Life at 105°C with Rated Voltage and Ripple Current the DUT will meet the following conditions					
		Capacitance Change	Within ± 20% of initial value				
		Leakage Current	Less than the specified value				
		Dissipation Factor	Less than 200% of specified value				
8	Shelf Life	After 1000 Hours Shelf Life at 105° C and thereafter pre-treatment as per IEC 384-1 the DUT will meet the following conditions					
		Capacitance Change	Within ± 20% of initial value				
		Leakage Current	Less than the specified value				
		Dissipation Factor	Less than 200% of specified value				
9	Other Details	As per IEC 384-4					

Dimensions and PCB Footprint

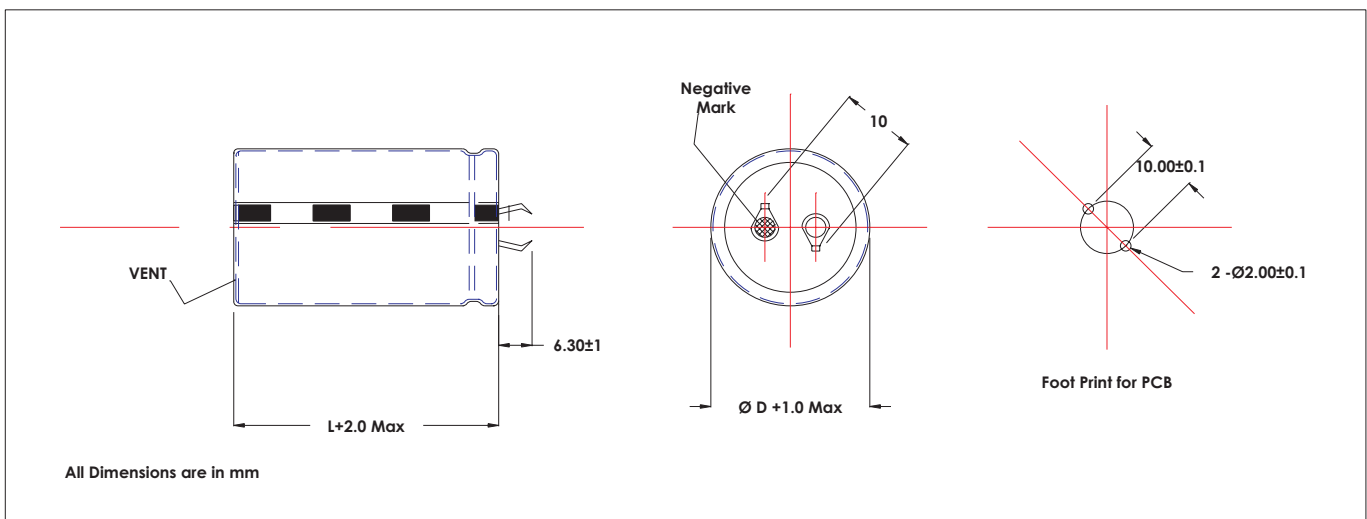

PSX Series Selection Guide: Can Sizes and Ripple Current Ratings

Vdc μF	16V		25V		35V		50V		63V		100V		160V	
	DxL	Ripple	DxL	Ripple	DxL	Ripple	DxL	Ripple	DxL	Ripple	DxL	Ripple	DxL	Ripple
47														
100														
150														
220														
330													22x30	1.15
470											22x25	0.80	22x40	1.30
1000											22x40	1.45	25x50	2.10
1500											22x50	1.90	30x50	2.70
2200											25x50	3.10	35x50	3.65
3300					22x30	1.35	22x40	1.90	22x50	2.20	30x50	4.00		
4700			22x30	1.50	22x40	1.70	22x50	2.35	25x50	2.80	35x50	5.10		
6800			22x40	1.90	22x50	2.15	25x50	3.20	30x50	3.55	35x56	5.60		
10000	22x30	1.90	22x50	2.35	25x50	2.85	30x50	3.95	35x50	4.40	35x60	6.10		
15000	22x40	2.50	25x50	3.10	30x50	3.70	35x56	4.75	35x60	5.05				
22000	25x40	3.25	30x50	4.00	35x50	4.85								
33000														
47000														

Vdc μF	200V		250V		315V		350V		400V		450V			
	DxL	Ripple	DxL	Ripple	DxL	Ripple	DxL	Ripple	DxL	Ripple	DxL	Ripple		
47											22x30	0.35		
100					22x30	0.60	22x30	0.60	22x40	0.65	22x40	0.60		
150					22x40	0.75	22x40	0.75	22x50	0.80	22x50	0.70		
220	22x30	0.75	22x30	0.85	22x50	0.95	25x40	1.00	25x50	1.05	25x50	0.90		
330	22x30	1.10	22x40	1.20	25x50	1.20	30x50	1.20	30x50	1.25	30x50	1.25		
470	22x40	1.30	22x50	1.50	30x50	1.60	35x50	1.65	35x50	1.70	35x50	1.55		
1000	30x50	2.00	35x50	2.15	35x56	2.10								
1500	30x50	3.80												
2200	35x56	3.65												
3300														
4700														
6800														
10000														
15000														
22000														
33000														
47000														

Multipliers Table for Ripple Current Specification

Parameter	50 Hz	100 Hz	1K Hz	10K Hz	105°C	85°C	65°C
Coefficient	0.8	1.0	1.3	1.5	1.0	1.7	2.1

Abbreviations Used:- D: Diameter in mm, L: Length of Aluminum Case in mm

Ripple Current: Maximum Rating, in Amperes at rated Operating Temperature and rated Operating Voltage